



LOWER NAZARETH TOWNSHIP

BOARD OF SUPERVISORS

623 MUNICIPAL DRIVE
NAZARETH, PA 18064
TELEPHONE: 610-759-7434
FAX: 610-746-3317

July 23, 2018

Dear Resident:

Lower Nazareth Township is about to embark on a road maintenance project in your neighborhood. The project will involve the micro-surfacing of the following roads:

T-559 SCHOOL HOUSE RD	Mountain view Rd to Dead End
T-557 MOUNTAINVIEW RD	SR 3020 to Mountain View Rd
T-544 HIGHVIEW DRIVE	SR 946 to School House Rd
T-558 VISTA DRIVE	SR 946 to School House Rd
T-553 MIDLAND ROAD	SR 946 to Dead End
T-554 MIDLAND CIRCLE	Midland Road to CUL_DE_SAC
T-527 HILL CREST AVENUE	Steuben Road to Manor Drive
T-531 GABLE DRIVE	Park Avenue to Circle Drive`
T-529 WOODLAWN DRIVE	Steuben Road to Gable Drive
T-530 PARK AVENUE	Steuben Road to Manor Drive
T-543 LISA DRIVE	Park Avenue to Hill Crest Avenue
T-542 MARIA DRIVE	Park Avenue to Circle Drive
T-528 CIRCLE DRIVE	Hill Crest Avenue to 80'CUL_DE_SAC
T-550 HILLTOP CIRCLE	Hill Crest Avenue to 80'CUL_DE_SAC
T-596 LITTLE CREEK DRIVE	Steuben Road to 80' CUL_DE_SAC
T-539 OAKWOOD LANE	Georgetown Rd to End of Roadway
T-538 DOGWOOD LANE	Oakwood Lane to Georgetown Rd
T-540 BIRCH DRIVE	Dogwood Lane to Dead End
T-541 ELM DRIVE	Oakwood Lane to Dogwood Lane
T-537 MAPLE DRIVE	Dogwood Lane to Dead End
T-562 LOCUST LANE	Pine Drive to Hemlock Lane
T-536 PINE DRIVE	Georgetown Rd to Hemlock Lane
T-564 SPRUCE LANE	Pine Drive and Locust Lane
T-563 LARCH LANE	Locust Lane to Hillview Drive

The commencement of the project will take place within the next few weeks. A precise start time is not yet available. Please watch the Township website (www.lowernazareth.com) for updates on the actual project start date. We will post the information on the Home Page under "Important Announcements" as it becomes available. In addition, the project contractor is responsible for notifying all properties of the commencement of work for those affected areas. It should take approximately one week to ten days to complete the entire project. The contractor will be required to close the roads that are being worked on for several hours until the micro-surfacing application is suitable for vehicle traffic. Only roads

that are worked on a particular day will be closed on that day. In the event of an emergency, emergency vehicles will still have access to your homes throughout the duration of the project. Please plan accordingly.

In addition, ON STREET PARKING WILL BE PROHIBITED FOR THE DURATION OF THE PROJECT BETWEEN THE HOURS OF 6 AM AND 6 PM. IT IS IMPERATIVE THAT NO VEHICLES BE IN THE ROADWAY DURING THE MICRO-SURFACING PROJECT. ANY VEHICLES ENCOUNTERED WILL BE REMOVED AT THE EXPENSE OF THE OWNER.

One additional note: If this project is underway while school is in session, we would like to make a cautionary statement that children and adults alike who are walking or driving to a bus stop should be keenly aware of the road closures and plan accordingly. In the event the project impacts school traffic, Lower Nazareth Township will work closely with the Nazareth Area School District in order to minimize inconvenience.

IMPORTANT MAILBOX INFORMATION We ask that every property owner inspect their mailbox location prior to commencement of the project. It is imperative that the face of your mailbox not protrude over the edge of the existing pavement. A protruding mailbox significantly interferes with the construction process. The interference can cause damage to your mailbox from construction equipment as well as compromise the integrity of the reconstruction and resurfacing of the roadway. We have enclosed a copy of the USPS mailbox standards for your use if you need to relocate your mailbox. Please note the set-back requirement of 6 to 8 inches. Any mailbox that is determined to protrude beyond the edge of the existing paving at the commencement of the project will be removed and relocated at the property owner's expense. The costs for this work will be based on time and materials.

TREE AND BUSH TRIMMING In preparation for the upcoming project, we ask that you trim all trees, shrubs and bushes that are encroaching the roadway. We ask that the vegetation be trimmed back to at least **one foot behind the edge of the roadway to a height of at least fifteen feet**. This will allow all equipment to pass through and complete their work unimpeded.

In closing, we would like to thank everyone in advance for their cooperation while this major road maintenance project is taking place. Every effort is being made to minimize the inconvenience to our residents.

Lower Nazareth Township

Quick Tools

Ship a Package

Send Mail

Manage Your Mail

Sf

Manage Your Mail

- Track
- Find Locations
- Change of Address
- Premium Forwarding Service
- Hold Mail
- Schedule a Redelivery
- Intercept a Package

Get help to...

- Forward Mail
- Reserve or Renew a PO Box
- Learn About Package Intercept
- Learn About Free Product Samples
- Learn About Catalogs

Learn About Mailbox Guidelines

Manage Mail for the Deceased

Mailbox Guidelines

So what makes a good mailbox?

From the wear and tear of daily use to constant assault from the elements, these guidelines will help you set up a mailbox that stands up to it all.

If you're buying a new mailbox, look for the Postmaster General's seal of approval; every new mailbox design should be reviewed and approved before it goes to market.

If you opt to construct your own mailbox, you should run your plans by your local postmaster. Overall, the mailbox you build will need to meet the same size, strength, and quality standards as manufactured boxes.

The house or apartment number should be clearly displayed on your mailbox. And, if your mailbox is on a different street than your house, the street name should appear on it, too.

Placement	The Post	Maintenance	Door Slots
-----------	----------	-------------	------------

Because of varying road and curb conditions, the Postal Service™ recommends that you contact your local postmaster for approval of the location of your mailbox before you put it up.

Put a roadside mailbox where a carrier can safely reach inside without leaving the truck. That means positioning it about 41" to 45" off the ground and back about 6" to 8" from the curb. In the absence of a raised curb, contact your local postmaster for guidance.

If you live in the city and are attaching the box to your house, just make sure it can be accessed easily from your sidewalk, steps, or porch. Because city carriers often shoulder heavy bags, put your mailbox about 4' from the ground. That way, your carrier won't have to stretch or bend to reach it. And remember to keep the path to your mailbox clear in inclement weather.

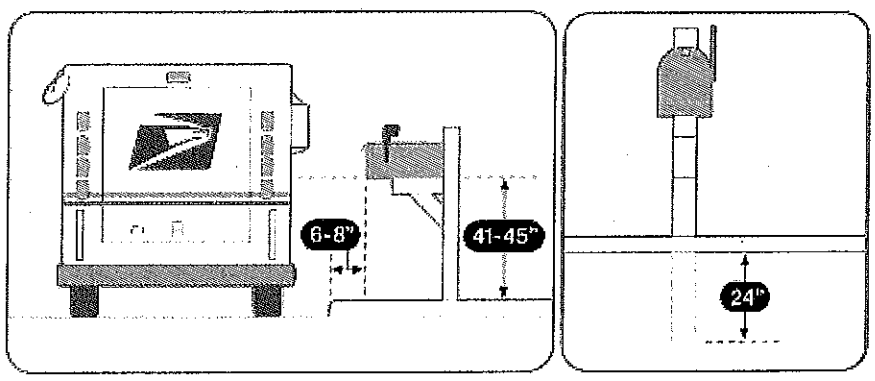

If you're mounting a curbside mailbox on a post near the street, the support should be secure and safe. The best supports are designed to bend or fall away if a car hits them.

The Federal Highway Administration recommends...

- A wooden mailbox support no bigger than 4" x 4"
- A 2"-diameter standard steel or aluminum pipe

Bury your post no more than 24" deep, so it can give way in an accident.

Don't use potentially dangerous supports, such as...

- Heavy metal pipes
- Concrete posts
- Farm equipment, such as milk cans filled with concrete

In areas with lots of snow, we suggest a semi-arch or extended arm-type support. That way, snowplows will be able to sweep under without knocking it down.